

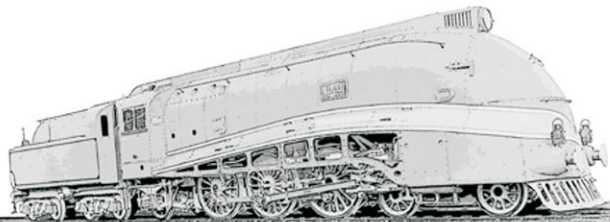

Al-Burhan Group
your route to Iraq



Railway Division





About Us

Al-Burhan is one of the biggest and most diversified construction and trading companies in Iraq. With sectors ranging from heavy machinery procurement to infrastructural engineering; the Group has an unrivalled depth of experience in Iraq carrying out projects of any size and complexity for public and private clients.



Al-Burhan Group
your route to Iraq

Baghdad | London | Amman | Dubai

The nation of Iraq is undergoing a massive phase of expansion particularly in the construction and public infrastructure sectors. Al-Burhan Group aims to play its part in the modernisation and rehabilitation of Iraq's infrastructure. From thermal power stations to state-of-the-art airports; the Group has consistently built on its years of practice with technical ingenuity and innovation.

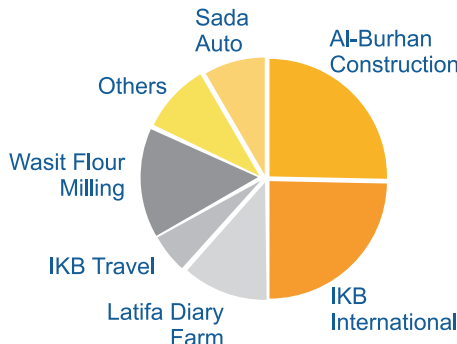

Our Dubai Office in the Fortune Tower

From construction equipment to railway development, the Group's driving philosophy is to successfully compete in the global construction industry. A main part of this strategy was the amalgamation of a diverse portfolio of companies in order to create Al-Burhan Group.

Bringing together the capabilities and skills of these various companies allows the Group to compete internationally on an unprecedented level.

Al-Burhan Group Divisions

Aviation



Al-Burhan Group has an well developed division in the field of aviation infrastructure construction and management services; a rapidly growing sector in modern Iraq.

Construction



Contracting and construction forms a key part of Al-Burhan Group with a diverse range of capabilities in planning, implementing and rehabilitating building projects.

Electricity



Al-Burhan Group with its technical and engineering expertise helps facilitate the construction and modernisation of power generation facilities and networks.

Agricultural Services



Al-Burhan Group as part of its diverse business portfolio designs and operates industrial scale agricultural facilities in Iraq serving the growing needs of the national population.

General trade



Aside from its specific technical sector, Al-Burhan Group also encompasses a wide range of other services from machinery servicing to spare parts sourcing and provision.

Railway



Al-Burhan Group provides railway consultancy, planning and construction services encompassing network building and renewal as well as rolling stock provision.

Travel



Through IKB Travel, Al-Burhan Group provides customers with airline tickets to Iraq and other global destinations as well as custom tours, from its London office in Edgware Road.

Consultancy Services



Al-Burhan Group provides a wide range of business support services. The company can assist with commercial, financial, legal and technical consultative requirements.

AI-Burhan Group Railway

AI-Burhan Group's Railway division consists of five departments covering the project requirements of the Iraqi Republic Railways (IRR) as follows:

Department 1
Department for Railway Design

Department 2
Department for Railway Concrete Sleepers

Department 3
Department for Supply of Heavy Machinery and Equipment

Department 4
Department for Maintenance and Spare Parts

Department 5
Department for Rehabilitation of Coaches and Workshops

A number of specialist engineers and consultants have been appointed to each department to direct the projects and to achieve results. Many of our engineers and consultants are ex-employees of Iraqi Republic Railways who have an unrivalled depth of experience in the railway sector.

AI-Burhan Group works with globally renowned companies to bring projects from conception to completion in accordance with international standards and expectations.

ABG Scope of Railway Services:

- ▶ Construction of new railway lines
- ▶ Installation of machinery & equipment
- ▶ Commissioning of locomotives & equipment
- ▶ Training of Iraqi engineers and consultation provision
- ▶ Soil investigation & surveying
- ▶ Supply of concrete sleepers
- ▶ Railway design and modernisation
- ▶ Supply of engineering equipment & machinery
- ▶ Commissioning of coaches and locomotives

Future Project: Baghdad Loop Line

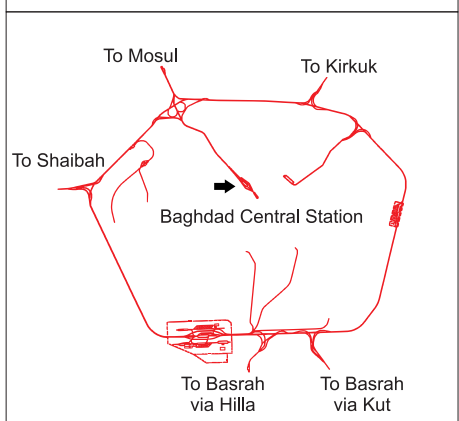

More details on Page 17

Railway Design

Department 1:

Al-Burhan Group has a long established history of cooperation for example with Iraqi Republic Railways (IRR). Utilising an experienced team of consultants, architects, engineers and planners, the Group is in a position to undertake railway construction and rehabilitation projects at short notice. There is unprecedented demand for railway engineering solutions in Iraq today. Al-Burhan Group has grown quickly providing services for the Iraqi national railway network over the last sixty years.

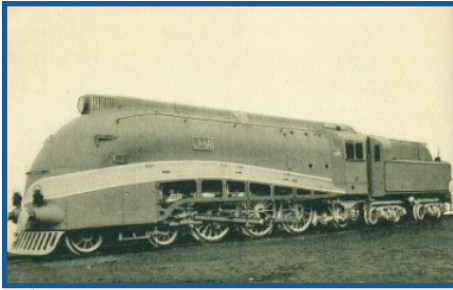

20th Century British 'Pacific' Steam Engine

The railway network of Iraq is in urgent need of expansion and modernisation. The system connects Baghdad to the wider region and is utilised for the import and export of cargo and goods as well as the transportation of passengers throughout Iraq.

IRR in collaboration with Al-Burhan Group is currently undertaking a number of projects on various scales with an overall aim of expanding the network as rapidly and efficiently as possible.

Some Key Projects:

Mussaieb – Kerbala – Najaf – Samawa Railway Project
246 km

Loop line around Baghdad Railway Project – Double Line
140 km

Baghdad – Baquba – Kirkuk – Erbil – Mawsol Railway Project
Double Line
555 km

Baghdad – Kut – Umarah – Basrah – Um Qaser Railway Project
Double Line
910 km

Mosel – Duhuk – Zakho – Turkey
Double Line
167 km

Kirkuk – Sulymaniya Railway Project – Double Line
118 km

Kut – Baquba Railway Project
Double Line
250 km



IRR TE-114 | Locomotive

Some Key Projects:

Reconstruction of Al-Fatha Railway Project
1 km

Hjama-Sawa Railway Project
15 km

Basra-Fao Railway Project
110 km



Al-Fatha Railway Bridge Project



Railway Network of Iraq

Railway Concrete Sleepers

Department 2:

This department was established in 2004 to cope with the urgent national demand for railway sleepers for IRR's network maintenance and expansion of existing railways tracks.

The concrete sleeper factory was originally constructed in 1982 by Dow-Mac Ltd (U.K.) and operated by IHP of India. In 2004 the Al-Burhan Group started rehabilitation and reconstruction of the Concrete Sleeper Factory located in the Abu Ghraib area just outside Baghdad.

This is one of our most ambitious and prestigious projects to date completed with the technical assistance of United Kingdom based company RMS which manufactured the factory machines and equipment. This new factory will rival any other production facility in the world in terms of daily production capability. The factory has the capacity to produce over 2800 concrete sleepers per day.



Location of the Abu Ghraib Factory

Meeting the ever increasing demands of the Iraqi railway network is a driving ambition for Al-Burhan Group. In constructing the factory, the Group has assisted in reducing the need for import of railway materials into Iraq, adding to the country's growing manufacturing sector.

The computer controlled concrete batching plant which automatically and optimally mixes concrete was produced by the renowned Danish concrete technology company SKAKO.

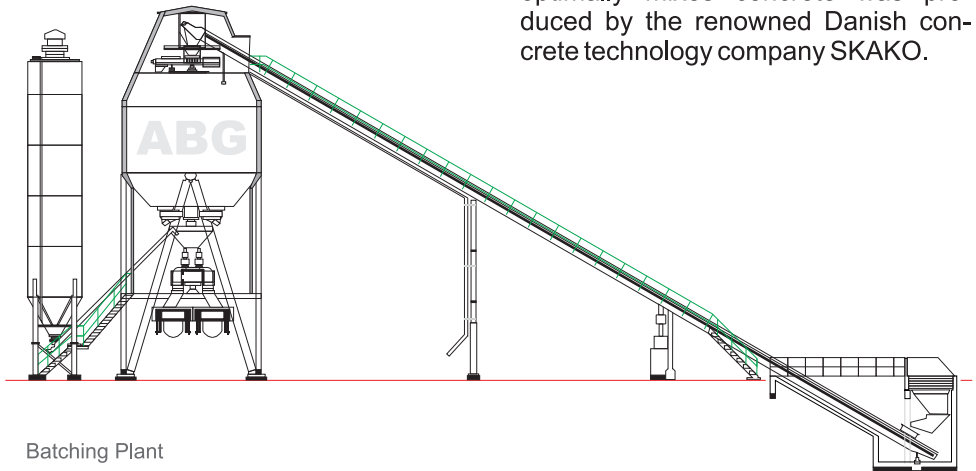

Batching Plant

Modern-day Iraq is experiencing an unprecedented level of growth in the passenger and cargo railway sector. Iraqi Republic Railways is determined to meet the needs of the nation through the undertaking of a massive railway expansion programme. Al-Burhan is proudly contributing to this through production at its Concrete Sleeper Factory in Abu Ghraib.



Abu Ghraib Concrete Sleeper Factory

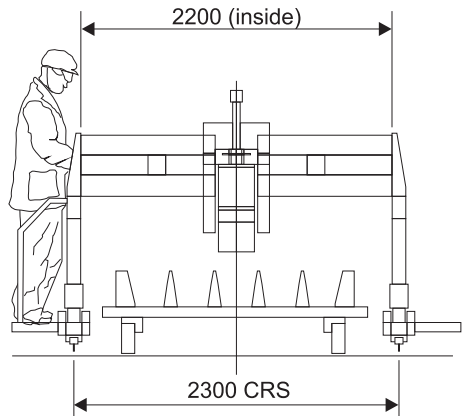
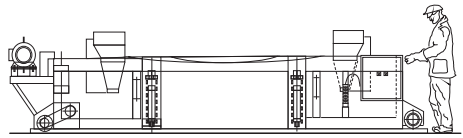

Factory Layout

- | | | | |
|--------------------------------|------------------------|------------------------|-----------------------|
| 1 Shoulders Store | 6 Laboratory | 11 Cafeteria and W.C | 16 Production Hall |
| 2 Consumables Store | 7 Maintenance Building | 12 Main Workshop | 17 Carpentry Workshop |
| 3 Construction Materials Store | 8 Scale | 13 Fuel Station | 18 Block Factory |
| 4 Maintenance Store | 9 Reception | 14 Electricity Station | 19 Batching Plant |
| 5 Power Generators Building | 10 Management | 15 Store No- 3 | 20 Water Tank |

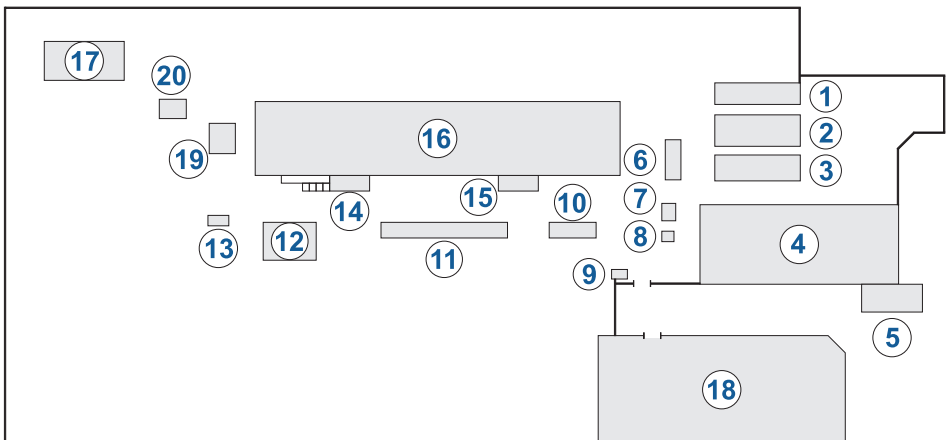

Supply of Heavy Machinery and Equipment

Department 3:

Al-Burhan Group has a long history of supplying specialist heavy machinery to public and private clients. From heavy duty 150 ton railway cranes to continuous track laying machines, Al-Burhan Group can undertake orders of any size and scope. The Group has formed long working relationships with

many advanced machinery manufacturers around the world giving it unrivalled access to equipment and machines. Meeting the demands of a rapidly growing railway sector in Iraq has taken the Group to every part of the world sourcing the most advanced and capable machinery and equipment.



















Locomotive of the Iraqi Republic Railways (IRR)



With Al-Burhan Group's capability and experience in railway and railroad construction; Pandrol the world's leading designer and manufacturer of rail fastenings and track support systems has granted Al-Burhan Group the sole agency for the Iraqi territory. Al-Burhan Group has proudly undertaken this role supplying high quality products to Iraqi Republic Railways (IRR).

Al-Burhan Group is the sole agent of Pandrol UK in Iraq

	<p>Automatic Clipping Machine (Pandrol Mark 4)</p>		<p>Mainline and Switch Tampers (Harsco - Model Mark 6700)</p>
	<p>Tamping and Levelling Machines (Harsco Mark VI)</p>		<p>Railway Ballast Regulator (Harsco - Model C154BR)</p>
	<p>Sand Removal Machines (Model 46-6)</p>		<p>Railway Sleeper Exchanger Machine (Harsco - Model 925)</p>
	<p>Rail Manual Fastening Clipping Machines (Model AP11-T6)</p>		<p>Mobile Crane (Model T775)</p>
	<p>Continuous Track Laying and Re-Laying Machine</p>		<p>Locomotives (DEM 2801 - 2830)</p>
	<p>Flash Butt Welding Machine (Model PRSM 5)</p>		<p>Flash Butt Welding Machine (Model PRSM 5)</p>
	<p>Casting Machine for Abu Ghraib Sleeper Factory</p>		<p>Railway Ganger Trolley equipped with Crane (Model: AGS-1)</p>
	<p>Dynamic Track Stabilizer (Harsco Model TS-30)</p>		<p>Nylon Insulators for Rail Fastening PR607</p>

Maintenance and Spare Parts

Department 4:

Al-Burhan Group has an advanced supply chain with a diverse group of specialist suppliers and product manufacturers to meet the exact requirements of its clients. From locomotives and sleeper carriages to replacement engines and gearboxes, the company can provide for any requested specifications in the railway industry.

Al-Burhan Group in addition to supplying complete machines; has a full

range inventory of spare parts and tools to provide support for its clients. A driving philosophy of the company is to maintain long term relationships with its customers; this entails providing prolonged support and technical assistance.

The Group utilises a global list of suppliers and maintenance engineers at short notice to keep its clients' machines in operation.

A selection of our previous deliveries:

Contractor	Iraqi Republic Railways
Supplier	CZ Loko – Czech Republic / ABG - Iraq
Period of Contract	6 months
Lot of Spare Parts	1 Set
Scope	One set of spare engine to suit T669.001 (DES 3101 Shunting loco which supplied between 1979 and 1982.
	

Contractor	Iraqi Republic Railways / MOU with UN
Supplier	Renengo - Russia / ABG - Iraq
Period of Contract	6 months
Lot of Spare Parts	1 Set
Scope	One set of spare parts for railway Cranes (GOTTWALD) 150 ton capacity.
	

Contractor	Iraqi Republic Railways
Supplier	Pandrol - UK/ ABG - Iraq
Period of Contract	6 months
Lot of Spare Parts	1 Set
Scope	Supply of British made Nylon Liner Insulator type (Pandrol) for (PR607a) rail fastening for maintenance for tracks that use the PR607 system.
	

Contractor	Iraqi Republic Railway
Supplier	Kalugaputtmarsh, Russia / ABG - Iraq
Period of Contract	6 months
Lot of Spare Parts	2 Sets (1 for PRSM4 and 1 for PRSM5)
Scope	Two sets of spare parts of Russian and Ukrainian origin.
	

Contractor	Iraqi Republic Railway
Supplier	Harsco Track Technologies USA / ABG Iraq
Period of Contract	6 months
Lot of Spare Parts	4 Sets for (C154BR, 6700, ST-30 and 925)
Scope	Four sets of spare parts of American origin to support the operation and maintenance of Harsco Tracks in Iraq.
	

Rehabilitation of Rolling Stock

Department 5:

Four main workshop facilities for heavy maintenance of rolling stocks (locomotives, wagons and coaches) are available for Iraqi Republic Railways in collaboration with Al-Burhan Group to use. These workshops are located at (Baghdad, Baji, Samawa and Al-Qaim) In addition there are eight workshops for light main-tenance at Baghdad, Fallujah, Ramadi, Haqlaniya, Akashat, Kirkuk, Mosul and Basra. Iraqi Republic Railways has a wide selection of the following rolling stock many of which are in need of modernisation or replacement.

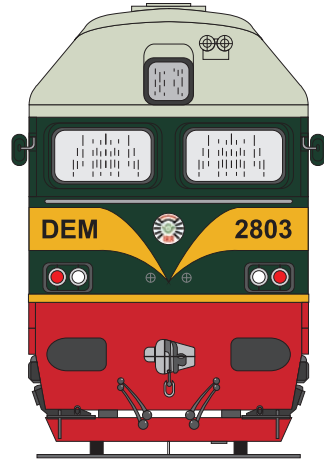

Type	Total Number	Number in Service
Main line Locomotives	143	86
Shunting Locomotives	82	39
Passenger coaches	186	43
Freight wagons	7500	2460





Natural Paints:

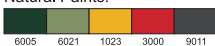

Past Business Operations

Over the past few years Al-Burhan Group has proudly executed many large and important contracts. A notable example is the manufacture of the complete main line Diesel Engine Locomotive constructed in Ukraine and delivered to Iraq. The first unit was commissioned in November 2003 with subsequent orders successfully fulfilled. To date the production and delivery of 30 units been completed.

A significant part of Al-Burhan Group's services include the adaptation of modern equipment with older industrial standards. Using its long history of practical experience the Group recently fulfilled an order for the Iraqi Republic Railways by renovating their existing and dated rolling stock ready for the demands of the modern and expanding rail infrastructure of Iraq.



IRR Locomotive & Track Laying Crane



Abu Ghraib Concrete Sleeper Factory

From track laying machines to mobile railway diggers; Al-Burhan Group can fulfil orders within record time scales as well as provide training and expertise in optimal machine operation.

Al-Burhan Group's diverse and knowledgeable team of experts have a well-earned reputation for adaptability, ingenuity and resourcefulness in meeting the varied and complex demands of their clients.

Production and Delivery of Concrete Railway Sleepers



Al-Burhan Group has completed several large orders of concrete sleepers for Iraqi Republic Railways. Previously the sleepers had been produced in collaboration with suppliers from neighbouring countries; however the Group is in the final stages of starting mass-production of sleepers at its own new high-capacity facility in Abu Ghraib.

Sand Removal Machines



The Kershaw Sand Removal Machines are manufactured in the United States by Kershaw/Progress Rail, a Railway Division of Caterpillar. They will provide a fast and efficient means of managing drifting sand on IRR tracks and are needed in western Iraq where sand covers the railway tracks extensively disrupting national transportation systems.

*To find more details, please log onto our website.

Our Philosophy

AI-Burhan Group's performance and ability to take on large projects has enabled us to gain a respected position in the Iraqi market. Our logo and name is trusted worldwide for reliability and quality of service. We pride ourselves on being one of the most successful and organised company in the territory of Iraq. This was demonstrated in 2004 when AI-Burhan Group received an award from Iraqi Ministry of Transport for high quality of service.

In addition the Group received an award for reliability from the Iraqi Ministry of Trade. AI-Burhan Group has received many awards in the past demonstrating its capabilities and efficiency of service to its clients.

The strength and capability of AI-Burhan Group has recently increased with the completion of several large scale projects. The Group is now globally trusted to take on projects of massive scale and complexity.



One of the Group's primary aims is to compete with global competitors in all forms of provision of railway supplies, equipment and machinery. Part of this goal is to make a significant contribution to the railway infrastructure of Iraq which is experiencing rapid growth in demand which must be met to guarantee a prosperous economic future for the country.



Some of ABG's major international ties

AI-Burhan Group has made rapid progress in the last few years of its involvement in the railway industry. The Group collaborates with a renowned assortment of global consortia always working to international standards and optimum practices.

As part its service provision the Group aims to aims to continue its position as a market leader in Iraq. Ever since the start of the first Burhan company over 60 years ago; AI-Burhan Group has been following on that auspicious beginning with continued growth and expansion. As a result the Group has established a modern, dynamic relationship with every corner of the globe embodying the company's motto '*Your route to Iraq.*'

Baghdad Loop Line Railway Project

Al-Burhan Group has taken a leading role in a large infrastructural project assisting the Iraqi Government with its aim of developing and expanding Iraq's transport infrastructure network. Iraqi Republic Railways plans to upgrade Baghdad's transport infrastructure by facilitating the construction of a 112 km loop line railway track surrounding the capital, Baghdad. It will be capable of moving both passengers and cargo freight quickly and efficiently throughout the city.

order to formally submit a pre-qualification bid to the client; Iraqi Republic Railways (IRR). The consortium members each have specific roles that they plan to bring to the project: Al-Burhan Group will be responsible for the supply of concrete sleepers (from its own factory in Abu Ghraib), supply of materials and local work as well as providing facilitation and representation for the consortium to State representatives.

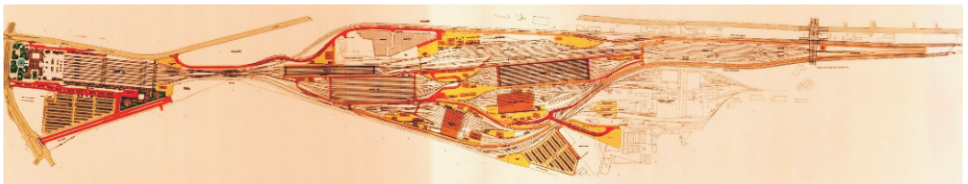

Baghdad Central Station (cross-section view)

The main elements of the multi-billion dollar project consist of a new Central Station, new East Station, six interchanges, two bridges, signalling and almost 300 km of track in total. The company has formed a consortium with several prominent international firms in

ABG brings to the consortium a wealth of experience in conducting large scale railway projects in Iraq. The construction of the Loop Line would be a significant addition to the illustrious construction portfolio of Al-Burhan Group.

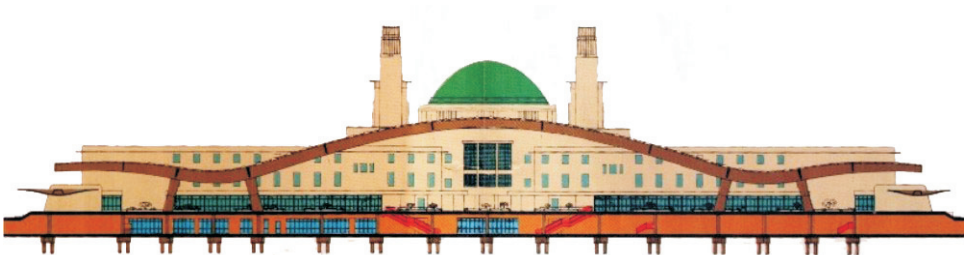

Baghdad Central Station



Head Office

Al-Burhan Group (Baghdad)
Compound 20
Kindy street, Mahala 213
Baghdad
IRAQ

Tel: 00964 (01) 541 1320
Fax : 00964 (01) 542 8603

BIAP Office

Baghdad International Airport
Samara Building
Ground Floor - Departure
Baghdad
IRAQ

Tel: 00964 (0) 781 531 1323
Tel: 00964 (0) 740 049 6605

Branch Offices

Al-Burhan Group (Baghdad)
Aldafteri Building
Salah Aldeen Alsabagh Street
Baghdad
IRAQ

Tel: 00964 (0) 1 541 1320
Fax: 00964 (0) 1 542 8603

Al-Burhan Group (London)
230 Edgware Road
London
W2 1DW
UK

Tel: 0044 (0) 20 7724 8455
Fax: 0044 (0) 20 7724 8787

Al-Burhan Group (Amman)
Al-Madeena Al-Munwara St.
Al- Dana Trading Centre
Amman
JORDAN

Tel: 00962 (0) 6 585 5978
Fax: 00962 (0) 6 554 0879

Al-Burhan Group (Dubai)
Sheikh Zayed Road
Fortune Tower - Office No. 610
Dubai
UAE

Tel: 00971 (0) 4 438 9546
Fax: 00971 (0) 4 438 9541